



Series :

CF8(SS304)

:GBV2F0BA15 + AT00 D

CF8M(SS316)

:GBV2F1BA15 + AT00 D

WCB(CARBON STEEL)

:GBV2F3BA15 + AT00 D

**PNEUMATIC FLANGED DOUBLE ACTING
ACTUATOR BALL VALVE FLANGES END ANSI
150#**

SPECIFICATION

- VALVE DESIGN :API 608
- VALVE INSPECTION AND TESTING :API 598;
- FLANGE :ASME B16.5
- THE VALVE FACE TO FACE :ASME B16.10

APPLICATIONS

- Process Industries: Oil and gas, chemical, pharmaceutical, and food processing

POS	PART NAME	MATERIAL		
1	BODY	CF8	CF8M	WCB
2	SCREW-BOLT	A193 B8	A193 B8	A193 B7
3	BONNET	CF8	CF8M	WCB
4	SEAT	PTFE	PTFE	PTFE
5	BALL	SS304	SS316	SS304
6	SEALING GASKET	PTFE	PTFE	PTFE
7	THRUST PAD	PTFE	PTFE	PTFE
8	O-RING	FKM	FKM	FKM
9	PACKING	PTFE	PTFE	PTFE
10	STEM	304	316	304
11	GLAND	CF8	CF8	WCB
12	RX-HEXAGONAL SCREW	A2-70	A2-70	A194 2H
13	NUT	A2-70	A2-70	A193 B7
14	HEXAGONAL NUT	A194 8	A194 8	A194 2H
15	PNEUMATIC ACTUATOR	ASSEMBLY	ASSEMBLY	ASSEMBLY

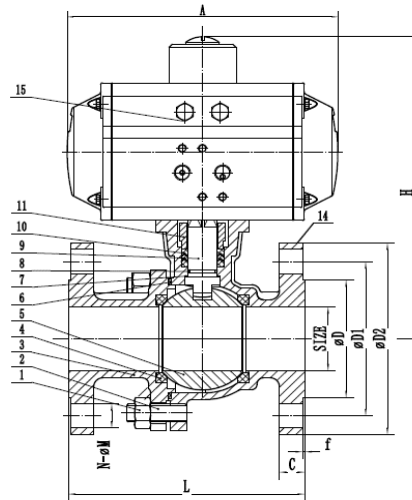

SIZE	1/2"	3/4"	1"	1-1/4"	1-1/2"	2"	2-1/2"	3"	4"	5"	6"
L	108	117	127	140	165	178	190	203	229	356	394
H	161	166	176	183	210	232	253	303	343	404	445
D	34.9	42.9	50.8	63.5	73	92.1	104.8	127	157.2	185.7	215.9
D1	60.3	69.9	79.4	88.9	98.4	120.7	139.7	152.4	190.5	215.9	241.3
D2	90	100	110	115	125	150	180	190	230	255	280
C	9.6	11.2	12.7	14.3	15.9	17.5	20.7	22.3	22.3	22.3	23.9
f	2	2	2	2	2	2	2	2	2	2	2
N-Ød	4-16	4-16	4-16	4-16	4-16	4-19	4-19	4-19	8.19	8-22	8-22
A	1630	163	163	163	214	252	252	316	354	418	450
ACTUATOR	AT50D	AT50D	AT63D	AT63D	AT63D	AT75D	AT75D	AT88D	AT100D	AT125D	AT145D

