



**Series :**

**CF8(SS304) : GBV2F0BP16 + AT00 D**

**CF8M(SS316) : GBV2F3BP16 + AT00 D**

**WCB(CARBONSTEEL) : GBV2F1BP16 + AT00 D**

**PNEUMATIC FLANGED MANUAL BALL VALVE FLANGES END PN16**

**SPECIFICATION**

- VALVE DESIGN : 1.3 GERMAN STANDARD DESIGN STANDARS
- VALVE INSPECTION AND TESTING : API 598
- FLANGE : EN 1092-1
- THE VALVE FACE TO FACE : ASME B16.34

**APPLICATIONS**

- Process Industries: Oil and gas, chemical, pharmaceutical, and food processing

POS	PART NAME	MATERIAL		
1	BODY	CF8	CF8M	WCB
2	SCREW-BOLT	A193 B8	A193 B8	A193 B7
3	BONNET	CF8	CF8M	WCB
4	SEAT	PTFE	PTFE	PTFE
5	BALL	SS304	SS316	SS304
6	SEALING GASKET	PTFE	PTFE	PTFE
7	THRUST PAD	PTFE	PTFE	PTFE
8	O-RING	FKM	FKM	FKM
9	PACKING	PTFE	PTFE	PTFE
10	STEM	304	316	304
11	GLAND	CF8	CF8	WCB
12	RX-HEXAGONAL SCREW	A2-70	A2-70	A194 2H
13	NUT	A2-70	A2-70	A193 B7
14	HEXAGONAL NUT	A194 8	A194 8	A194 2H
15	PNEUMATIC ACTUATOR	ASSEMBLY	ASSEMBLY	ASSEMBLY

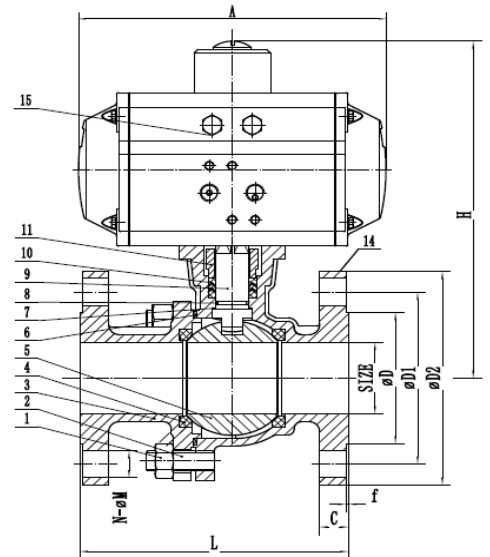

SIZE	1/2"	3/4"	1"	1-1/4"	1-1/2"	2"	2-1/2"	3"	4"	5"	6"
L	115	120	125	130	140	150	170	190	229	325	350
H	51	55	63	71	81	88	114	124	147	179	207
D	95	105	115	140	150	165	185	200	220	250	285
D1	60.3	69.9	79.4	88.9	98.4	120.7	139.7	152.4	190.5	215.9	241.3
D2	90	100	110	115	125	150	180	190	230	255	280
C	15	20	25	32	38	50	64	76	100	120	150
f	2	2	2	2	2	2	2	2	2	2	2
N-øh	4-14	4-14	4-14	4-18	4-18	4-18	4-18	8.18	8.18	8.18	8-22
A	9	9	11	11	14	14	17	17	17	22	27
ACTUATOR	AT50D	AT50D	AT63D	AT63D	AT63D	AT75D	AT75D	AT88D	AT100D	AT125D	AT145D

