



Series :

CF8(SS304) : GBV2F0BP16 + KST-00 A

CF8M(SS316) : GBV2F3BP16 + KST-00 A

WCB(CARBONSTEEL) : GBV2F1BP16 + KST-00 A

**ELECTRIC FLANGED BALL VALVE FLANGES
END PN16**

SPECIFICATION

- VALVE DESIGN : 1.3 GERMAN STANDARD DESIGN STANDARDS
- VALVE INSPECTION AND TESTING : API 598
- FLANGED : JIS B2220
- THE VALVE FACE TO FACE : JISB2002

APPLICATIONS

- control the flow of various fluids and gases in applications like oil and gas, water treatment, power generation, chemical processing, and industrial manufacturing

MATERIAL LIST

1	BODY	CF8	CF8M	WCB
2	SCREW BOLT	A193 B8	A193 B8	A193 B7
3	BONNET	CF8	CF8M	WCB
4	SEAT	PTFE	PTFE	PTFE
5	BALL	SS304	SS316	SS304
6	SEAL GASKET	PTFE	PTFE	PTFE
7	THUST PAD	PTFE	PTFE	PTFE
8	O-RING	FKM	FKM	FKM
9	PACKING	PTFE	PTFE	PTFE
10	STEM	304	316	304
11	GLAND	CF8	CF8	WCB
12	EX-HEXAGONAL SCREW	A2-70	A2-70	A194 B7
13	NUT	A2-70	A2-70	A193 2H
14	HEXAGONAL NUT	A194 8	A194 8	A194 2H
15	ELECTRIC ACYUATOR	ASSEMBLY	ASSEMBLY	ASSEMBLY

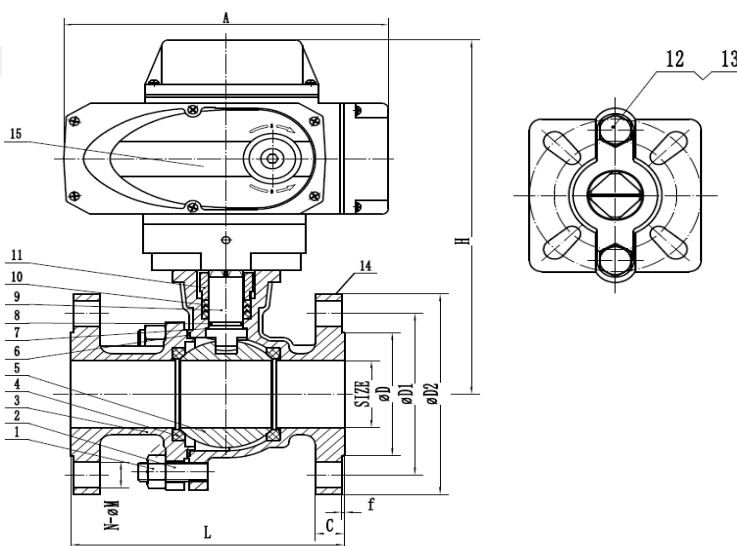

SIZE	DN15	DN20	DN25	DN32	DN40	DN50	DN65	DN80	DN100	DN125	DN150
L	115	120	125	130	140	150	170	180	190	325	350
H	51	55	63	71	81	88	114	124	147	179	207
D	95	105	115	140	150	165	185	200	220	250	285
D1	70	75	90	100	105	120	140	150	175	210	240
D2	95	100	125	135	140	155	175	185	210	250	280
C	15	20	25	32	38	50	64	76	100	125	150
f	2	2	2	2	2	2	2	2	2	2	2
N-M	4-14	4-14	4-14	4-18	4-18	4-18	4-18	4-18	8-18	8-18	8-22
A	9	9	11	11	14	14	17	17	17	22	27
ACTUATOR	KST-08A*	KST-08A*	KST-08A*	KST-08A	KST-08A	KST-08A	KST-08A	KST-15A	KST-25A	KST-40A	KST-60A

