

GENERAL SERVICE PRESSURE GAUGE

Model : GPG1

GPG1 model are designed for non-corrosive environment. Water, air, oil or gas services are the most common applications which do not have high viscosity and do not crystallize. It's suitable for pneumatic, filters, pressure regulators, hydraulic, compressors and etc.



Standard Specification

Dial Size

40, 50, 60, 75, 100, 150, 200, 250mm

Scale Range (kgf/cm², psi, bar, kPa, MPa)

40mm : 0 ~ 2 to 0 ~ 35 kgf/cm²
 50mm : -76cmHg ~ 0 to 0 ~ 100 kgf/cm²
 60mm : -76cmHg ~ 0 to 0 ~ 700 kgf/cm²
 75mm : -76cmHg ~ 0 to 0 ~ 300 kgf/cm²
 100mm, 150mm : -76cmHg ~ 0 to 0 ~ 300 kgf/cm²
 200mm, 250mm : 0 ~ 7 to 0 ~ 100 kgf/cm²

Working Pressure

75% of Full Scale

Accuracy

40mm : ± 3.0% of Full Scale.

50, 60, 75, 100, 150, 200, 250mm : ± 1.5% of Full Scale

Working Temperature

Ambient : -20 ~ 60°C
 Process : -20 ~ 60°C

Material

Case & Cover : Black Finished Steel
 Window : Glass
 Movement : Brass
 Element Tube : Brass
 Connection : Brass

Pressure Gauge Ordering Information

Model

GPG1

Mounting Type

A: Direct bottom connection
 B: Bottom connection with surface mounting plate
 D: Direct center back connection
 BD: Center back connection with panel mounting plate

Dial Size

40, 50, 60, 75, 100, 150, 200 or 250mm

Scale Range

Connection Type

1/8" BSPT, NPT, BSP
 1/4" BSPT, NPT, BSP
 3/8" BSPT, NPT, BSP
 1/2" BSPT, NPT, BSP

Options

Red Pointer

Example of Order

Model

GPG1

Mounting Type

(A)

Dial Size

75mm

Range

0~ 7 kgf/cm²

Connection

3/8" BSPT

Basic Dimensions

CODE A

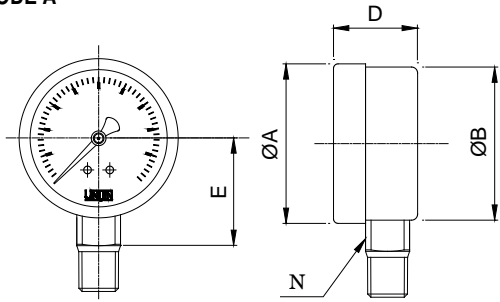

A: Direct bottom connection

Unit : mm

	ø 40	ø 50	ø 60	ø 75	ø 100	ø 150
A	42.0	52.4	63.3	81.0	106.0	150.0
B	40.8	50.8	61.6	80.0	105.0	148.0
D	23.0	28.0	29.1	35.6	35.6	47.0
E	27.4	32.7	40.6	51.8	66.8	90.0
N	11.0	14.0	14.0	17.0	17.0	22.0

CODE B

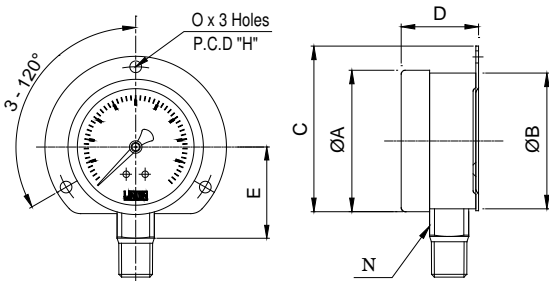

B: Bottom connection with surface mounting plate

Unit : mm

	ø 75	ø 100	ø 150	ø 200	ø 250
A	78.0	106.0	150.0	200.0	250.0
B	77.0	105.0	148.0	198.0	248.0
C	89.0	117.0	170.0	216.5	273.2
D	37.0	36.7	38.0	35.5	51.3
E	56.0	66.8	92.0	115.0	140.0
H	90.0	115.0	172.0	218.0	272.0
N	17.0	17.0	17.0	17.0	17.0
O	4.5	5.5	6.0	5.0	5.0

CODE D

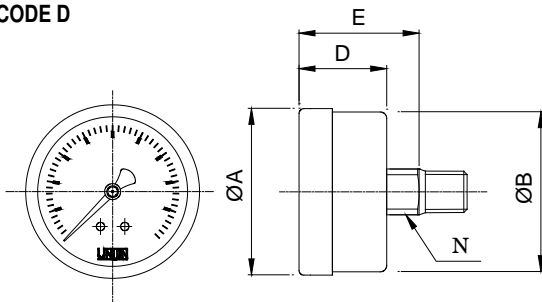

D: Direct center back connection

Unit : mm

	ø 40	ø 50	ø 60	ø 75	ø 100
A	42.0	52.4	63.3	78.0	106.0
B	40.8	50.8	61.6	77.0	105.0
D	24.5	28.0	29.8	35.0	35.0
E	28.7	35.0	34.4	47.3	46.5
N	11.0	14.0	14.0	17.0	17.0

CODE BD

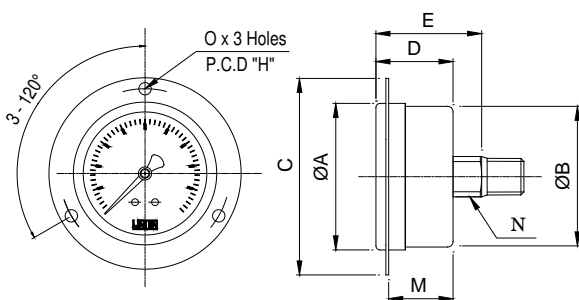

BD: Center back connection with panel mounting plate

Unit : mm

	ø 40	ø 50	ø 60	ø 75	ø 100
A	41.5	52.2	63.3	78.0	106.0
B	40.2	50.8	61.8	77.0	105.0
C	60.5	70.0	85.2	100.0	128.0
D	24.5	28.5	29.3	35.0	35.0
E	28.7	35.8	36.4	47.3	46.5
H	49.0	62.0	74.0	90.0	115.0
M	22.9	26.3	24.8	31.0	31.0
N	11.0	14.0	14.0	17.0	17.0
O	3.5	4.5	4.2	4.5	5.5