



K Series Scotch Yoke Pneumatic Actuator



Working Parameter:

Rotation Angle: 0-90°
Output Torque
Double Acting: 850-76300N.m.
Spring Return: 700-24300N.m.
Working Pressure:
Pneumatic: 3-8bar
Hydraulic: 30-100bar
Working Temp.:
Standard: -20°C--+80°C
Low Temp. D Type: -40°C--+80°C
High Temp. G Type: -15°C--+150°C

Model Preparation

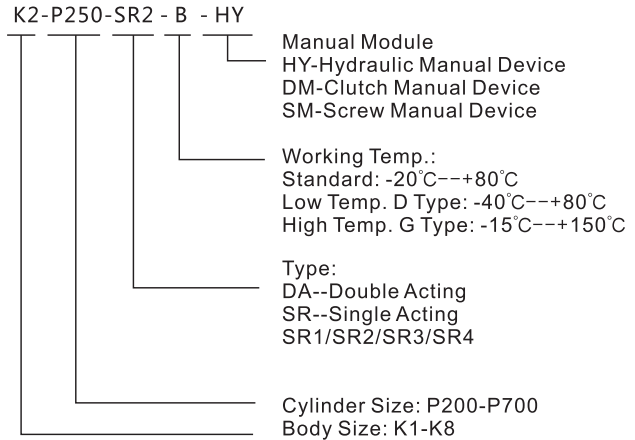

Modular design:

K-series actuators have functional modules such as pneumatic power, hydraulic power, spring power and manual control. All the functional modules are subject to inter-combination and exchange, so that users can choose various modules according to functional requirements of valve process control procedure. The modules can be purchased separately, reducing inventory of spare parts.

Safety:

K-Series pre-assembled spring module adopts the latest manufacturing process. It preassembles a spring in the modules, eliminating the spring of incidental release, removing potential risks, preventing malfunction and facilitating disassembly and installation.

Compact type:

K-series actuators integrate and optimize the center-of-gravity position, making the appearance more reasonable and light. Compared with other actuators with the same torque, it is lighter and need less installation space.

Water-resistant protection:

Complying with IP66 AND IP67 protection standards, all parts and components are equipped with O rings at their joints, which can effectively prevent water entering the case. It is able to withstand short-term or long-term immersion in water, so that users can make a choice according to requirements.

Wearing and lubrication:

The position where the piston rod and piston slide and rub is furnished with self-lubricating bearing. The piston rod is plated with hard chrome and is provided with fine grinding and finishing. The cylinder inner wall is coated with fine grinding by hard chromium plating. With such outstanding to the valve, which reduces friction and effectively improves the utilization efficiency of springs.

Corrosion resistance:

K-series actuators, with internal protection and external coating, are reliably applicable to all kinds of environments and are in compliance with relevant national standards.

Standardization:

The connection size of the top drive shafts of all K-series models is the same and is in compliance with NAMUR standard, so that it is easy to install such fittings as position switch, locator.

Valve installation:

As for the installation of K-series actuators and valves, flanges and shaft key connection, the size complies with the torque range specified ISO 5211 standard.



DESIGN FEATURES:

- 1. **Self-lubricating bearing of piston rod:** Functioning as lubrication and guide, it reduces the friction and increases the conduction.
- 2. **Fork rolling sleeve structure:** Two rolling sleeves made of bearing steel at the top and the bottom hold the fork and slide to and fro in the groove, changing the linear motion to rotary motion.
- 3. **Connection of standard valve:** The connection size of K-series valves is in compliance with torque range specified in the Standard ISO 5211.
- 4. **Spring module:** Pre-assembled spring module removes the spring of incidental release, eliminates potential risks and avoids maloperation.
- 5. **Locking-nut:** Locking-nut can prevent spring getting loose or coming off in vibration.
- 6. **Teflon coating in the cylinder bore:** With hi-tech new coating of PTFE material, it treated with special techniques and dried at high temperature.
- 7. **Piston guide ring:** Pneumatic fluorocarbon guide ring made up of the material made from teflon and carbon fiber functions to separate the cylinder and piston motions.
- 8. **Self-lubricating bearing of drive shaft:** Two self-lubricating bearings, mounted at the top and the bottom, functions to support and position, and rotate and rotate and lubricate.

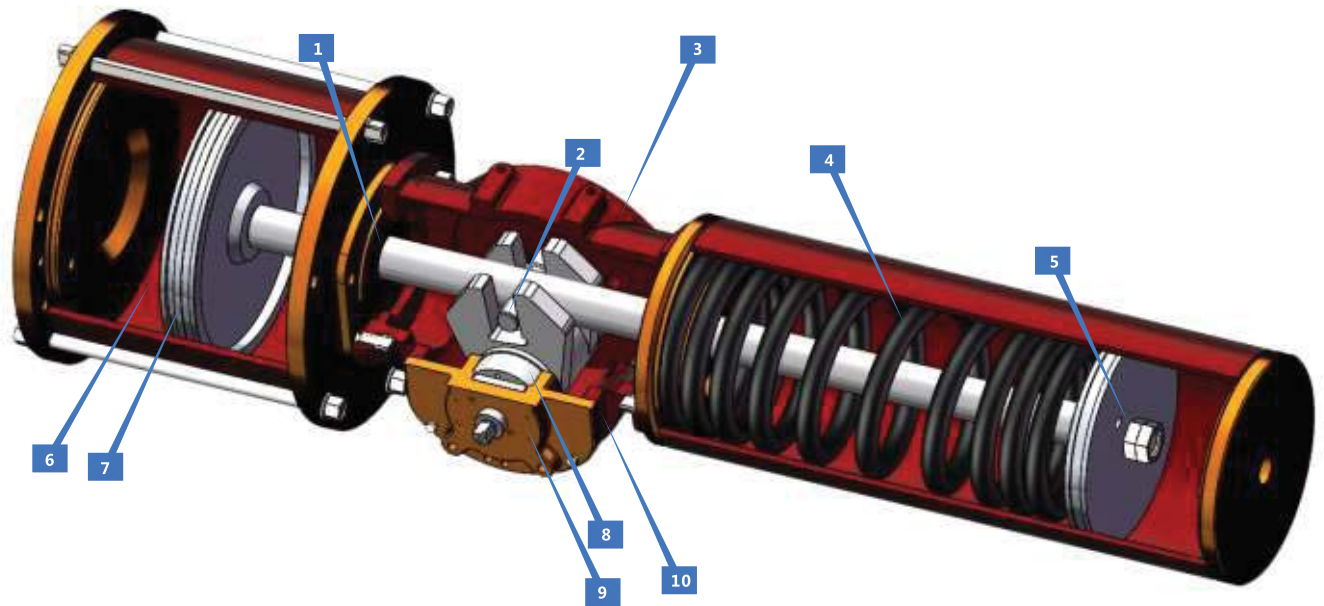
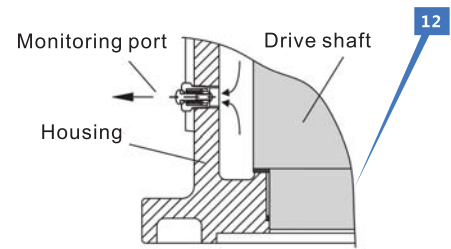
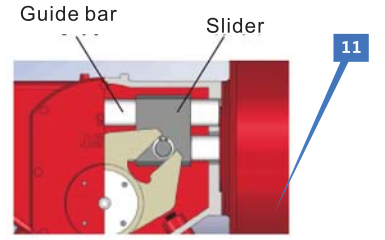

9. Connection of standard accessories: The interface of all the output accessories of K-series drive shaft is the same and is in compliance with NAMUR standard.

10. Stroke adjustment screw: K-series actuators have $\pm 5^\circ$ stroke control, so that it can freshly make adjustment within the stroke of $80^\circ - 100^\circ$.

11. Guide rod slipper: Models above K6 are furnished with such slider. Supported by the guide rod, the sliding slipper will push the fork to rotate the output shaft to run steadily.

12. Exhaust-air monitor: As the transmission module is totally sealed, a special exhaust-air monitor is designed to check over pressure release of pneumatic module and sealing leak, and prevent dust, corrosive atmosphere and water entering as well.

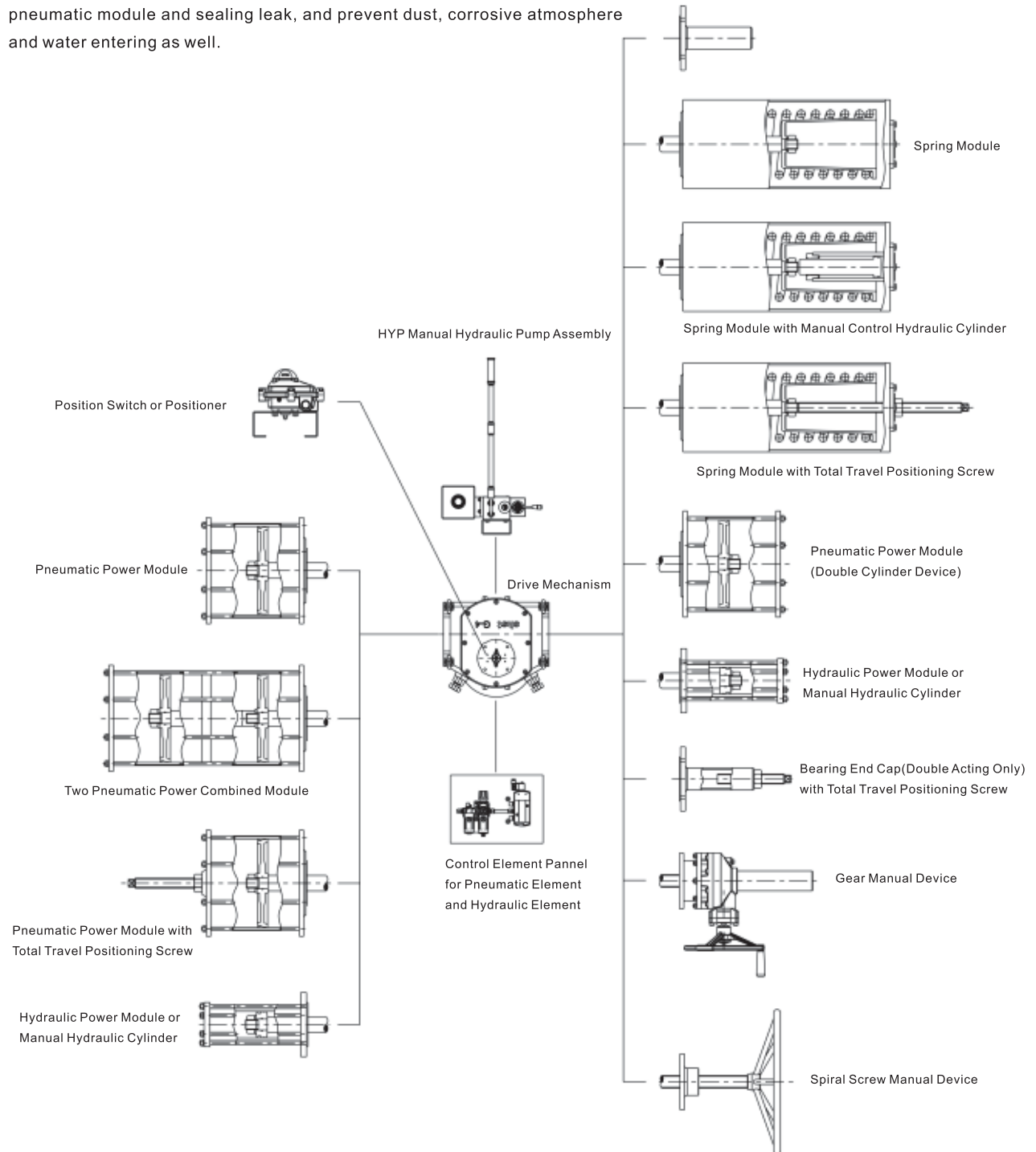

Parts and Material

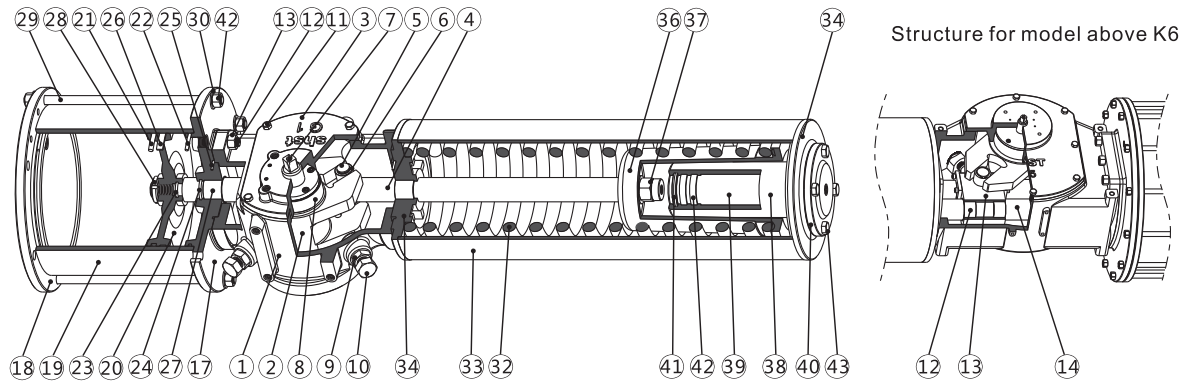

No.	Parts	Material
1	Body	Ductile Cast Iron
2	York	WCB
3	Cover	Ductile Cast Iron
4	Piston Rod	Cast Steel
5	Pin Shaft	Bearing Steel
6	Roll Sleeve	Bearing Steel
7	Output Shaft	Cast Steel (Chrome Plating)
8	Lubricant Bearing	Composite
9	Nut	Cast Steel
10	Adjust Stud	Cast Steel
11	Hexagon Stud	Cast Steel
12	Double Stud	Cast Steel
13	Nut	Cast Steel
14	Guide Rod	Cast Steel (Chrome Plating)
15	Support Slider	Cast Steel
16	Lubricant Bearing	Composite
17	Inside End Cap	Ductile Cast Iron
18	Outside End Cap	Ductile Cast Iron
19	Cylinder	Cast Steel (Chrome Plating)
20	Piston	Ductile Cast Iron
21	Piston O Ring	Rubber
22	End Cap O Ring	Rubber

No.	Parts	Material
23	O Ring	Rubber
24	O Ring	Rubber
25	O Ring	Rubber
26	Guide Ring	Composite
27	Lubricant Bearing	Composite
28	Locking Nut	Carbon Steel
29	Double Stud	Carbon Steel
30	Gasket	Carbon Steel
31	Nut	Carbon Steel
32	Compressed Spring	Spring Steel
33	Spring Steel	Carbon Steel
34	Spring Seat	Carbon Steel
35	Welding Flange	Carbon Steel
36	Spring Sleeve	Carbon Steel
37	Captive Nut	Carbon Steel
38	Hydraulic Cylinder	Cast Steel (Chrome Plating)
39	Plug	Cast Steel (Chrome Plating)
40	Hydraulic Flange	Cast Steel
41	Sealing Ring	Rubber
42	Guide Ring	Composite
43	Hexagon Stud	Cast Steel

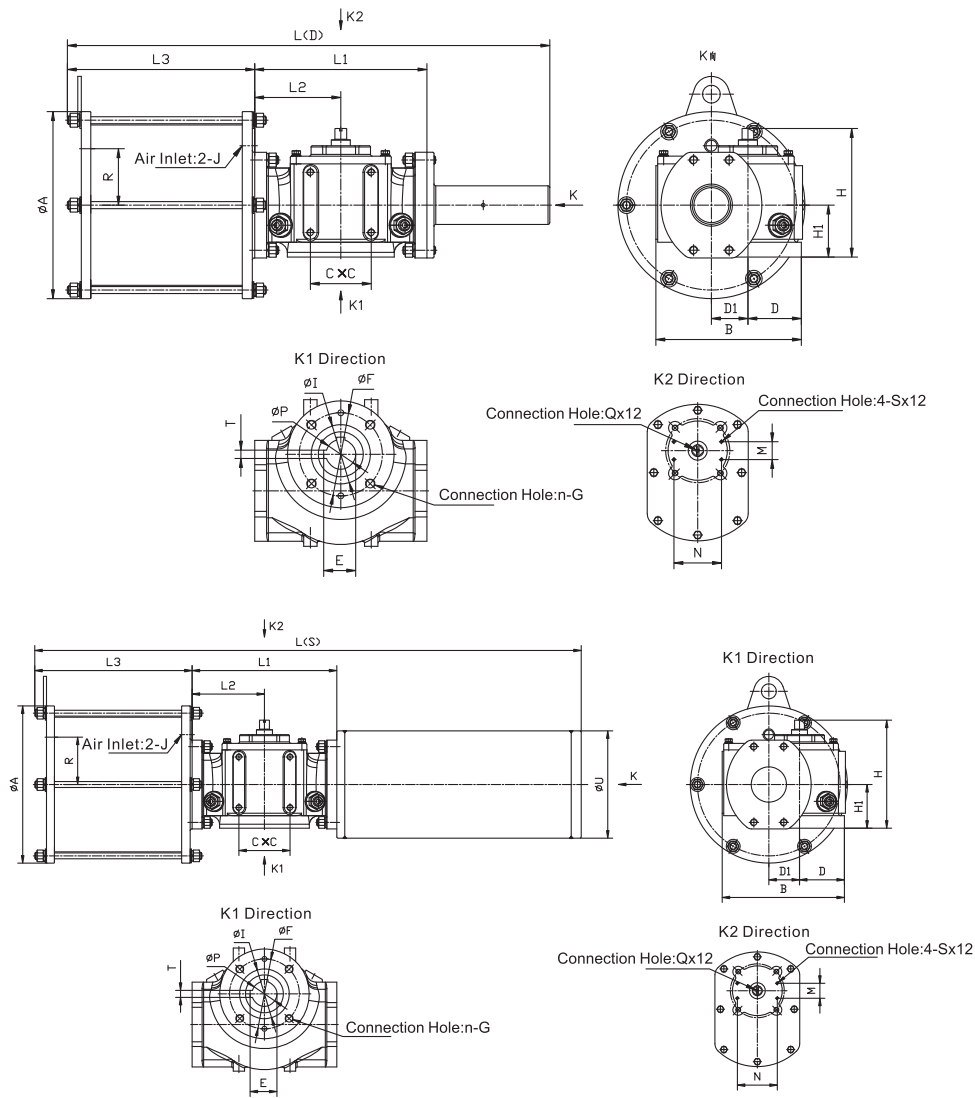

K Series Double Acting / Spring Return Pneumatic Actuator Dimension

Model	ISO5211	L(D)	L(S)	L1	L2	L3	H	H1	A	B	C	D
K1-P200	F10/F12	630	895	240	120	228	183	75	255	191	80×60	62.5
K2-P250	F14	812	1100	290	145	316	217	88	315	247	102	90
K3-P300	F16	917	1352	334	167	358	228	94.5	370	279	102	102.5
K4-P350	F25	1060	1518	390	195	403	265	108	420	355	102	150
K5-P400	F25	1060	1518	390	195	403	265	108	480	355	102	150
K6-P500	F30	1205	2270	476	238	565	308	130	600	430	102	175
K7-P600	F35	1580	2340	600	300	685	375	165	710	538	102	207.5
K8-P700	F35	1580	2340	600	300	685	375	165	830	538	102	207.5

Model	D1	E	F	n-G	I	J	M	N	P	Q	R	S	T	U
K1-P200	50	39.3	102/125	4-M10/M12	85	1/4"	30	80	36	M6	76	M5	10	166
K2-P250	61.5	53.8	140	4-M16	100	1/2"	30	80	50	M6	95	M5	14	202
K3-P300	75	64.4	165	4-M20	130	1/2"	30	80	60	M6	118	M5	18	244
K4-P350	90	76.9	254	8-M16	200	1/2"	30	80	72	M6	145	M5	20	297
K5-P400	90	76.9	254	8-M16	200	3/4"	30	80	72	M6	175	M5	20	402
K6-P500	110	127.4	298	8-M20	230	1"	30	80	120	M6	210	M5	32	480
K7-P600	140	170	356	8-M30	260	1"	30	80/130	160	M6	250	M5	40	530
K8-P700	140	170	356	8-M30	260	1 1/2"	30	80/130	160	M6	288	M5	40	560

K Series Double Acting Pneumatic Actuator Torque Table (N.m.)

Model	Spring Torque	Air Supply Pressure								
		3	3.5	4	4.5	5	5.5	6	7	8
K1-P200-DA	Open/Closed	823	960	1097	1234	1372	1509	1646	1920	2195
	Min	434	507	579	652	724	796	869	1014	1158
K2-P250-DA	Open/Closed	1576	1839	2101	2364	2627	2889	3152	3677	4203
	Min	832	971	1109	1248	1386	1525	1664	1941	2218
K3-P300-DA	Open/Closed	2769	3231	3692	4154	4615	5077	5539	6462	7385
	Min	1462	1705	1949	2193	2436	2680	2923	3411	3898
K4-P350-DA	Open/Closed	4533	5288	6044	6799	7555	8310	9066	10577	12088
	Min	2393	2791	3190	3589	3988	4386	4785	5583	6380
K5-P400-DA	Open/Closed	5949	6941	7932	8924	9916	10907	11899	13882	15865
	Min	3140	3664	4187	4710	5234	5757	6281	7327	8374
K6-P500-DA	Open/Closed	11468	13379	15291	17202	19113	21025	22936	26759	30581
	Min	6053	7062	8071	9080	10089	11098	12107	14124	16142
K7-P600-DA	Open/Closed	21006	24507	28008	31509	35010	38512	42013	49015	56017
	Min	11088	12936	14784	16632	18480	20328	22176	25872	29568
K8-P700-DA	Open/Closed	28645	33419	38193	42967	47742	52516	57290	66838	76386
	Min	15120	17640	20160	22680	25200	27720	30240	35280	40320

K Series Spring Return Pneumatic Actuator Torque Table (N.m.)

Model	Spring Torque	Air Supply Pressure								Spring Torque
		3	3.5	4	4.5	5	5.5	6	7	
K1-P200-SR2	Open	287	424	561	699	836	973	1110	1384	698
	Min	110	182	254	327	399	472	544	689	325
	Closed	125	262	399	536	673	810	948	1222	536
K2-P250-SR2	Open	548	811	1074	1336	1599	1861	2124	2649	1339
	Min	209	348	486	625	764	902	1041	1318	623
	Closed	237	499	762	1025	1287	1550	1813	2338	1028
K3-P300-SR2	Open	962	1424	1885	2347	2808	3270	3731	4654	2355
	Min	366	610	854	1097	1341	1585	1828	2315	1095
	Closed	414	876	1337	1799	2261	2722	3184	4107	1807
K4-P350-SR2	Open	1574	2329	3085	3840	4595	5351	6106	7617	3856
	Min	599	998	1397	1795	2194	2593	2992	3789	1793
	Closed	677	1432	2188	2943	3699	4454	5210	6721	2959
K5-P400-SR2	Open	2065	3056	4048	5040	6031	7023	8014	9997	5062
	Min	786	1309	1833	2356	2880	3403	3926	4973	2354
	Closed	888	1879	2871	3862	4854	5845	6837	8820	3884
K6-P500-SR2	Open	3979	5890	7801	9713	11624	13535	15447	19269	9759
	Min	1514	2523	3532	4541	5550	6559	7568	9585	4539
	Closed	1709	3621	5532	7443	9355	11266	13177	17000	7489
K7-P600-SR2	Open	7286	10788	14289	17790	21291	24792	28293	35295	17877
	Min	2773	4621	6469	8317	10165	12013	13861	17557	8315
	Closed	3129	6630	10131	13632	17133	20634	24135	31137	13720
K8-P700-SR2	Open	9936	14710	19484	24258	29032	33806	38580	48129	24379
	Min	3781	6301	8821	11341	13861	16381	18901	23941	11339
	Closed	4266	9040	13814	18588	23363	28137	32911	42459	18709

KAW Series Pneumatic Actuator Output Table (N.m.)

Model	Spring Torque	Air pressure (Bar)								
		3	3.5	4	4.5	5	5.5	6	7	8
K1AW-P200-DA	Open/Closed	1646	1920	2195	2469	2743	3018	3292	3840	4389
	Min	869	1014	1158	1303	1448	1593	1738	2027	2317
K2AW-P250-DA	Open/Closed	3152	3677	4203	4728	5253	5779	6304	7355	8405
	Min	1664	1941	2218	2496	2773	3050	3327	3882	4437
K3AW-P300-DA	Open/Closed	5539	6462	7385	8308	9231	10154	11077	12923	14769
	Min	2923	3411	3898	4385	4872	5360	5817	6821	7796
K4AW-P350-DA	Open/Closed	9066	10577	12088	13598	15109	16620	18131	21153	24175
	Min	4785	5583	6380	7178	7975	8773	9570	11166	12761
K5AW-P400-DA	Open/Closed	11899	13882	15865	17848	19831	21814	23797	27764	31730
	Min	6281	7327	8374	9421	10468	11514	12561	14655	16748
K6AW-P500-DA	Open/Closed	22936	26759	30581	34404	38227	42050	45872	53518	61163
	Min	12107	14124	16142	18160	20178	22196	24213	28240	32284

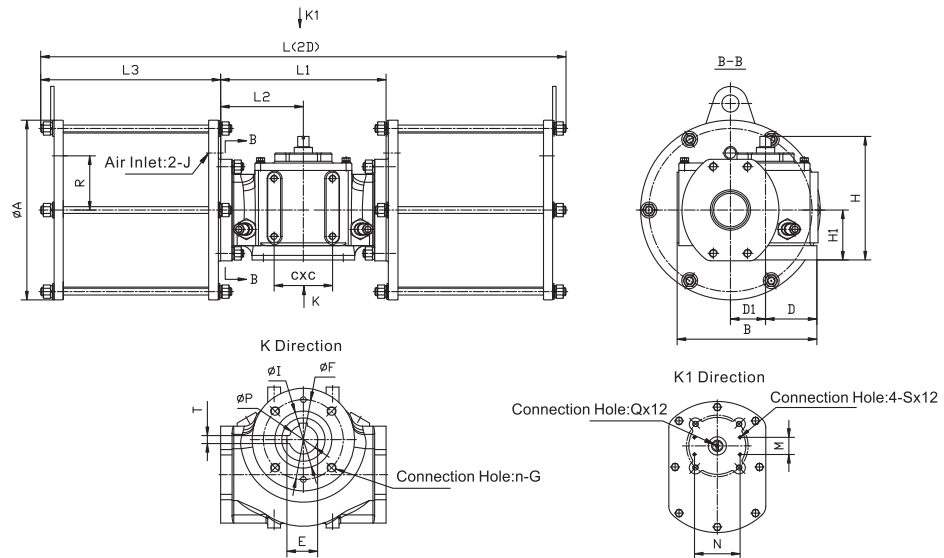

KAW Series Double Acting / Spring Return Pneumatic Actuator Dimension

Model	ISO5211	L(2D)	L1	L2	L3	H	H1	A	B	C	D	D1
K1AW-P200-DA	F10/F12	696	240	120	228	183	75	255	191	80×60	62.5	50
K2AW-P250-DA	F14	922	290	145	316	217	88	315	247	102	90	61.5
K3AW-P300-DA	F16	1050	334	167	358	228	94.5	370	279	102	102.5	75
K4AW-P350-DA	F25	1196	390	195	403	265	108	420	355	102	150	90
K5AW-P400-DA	F25	1196	390	195	403	265	108	480	355	102	150	90
K6AW-P500-DA	F30	1476	476	238	500	308	130	610	430	102	175	110

Model	E	F	n-G	I	J	M	N	P	Q	R	S	T
K1AW-P200-DA	39.3	102/125	4-M10/M12	85	1/4"	30	80	36	M6	76	M5	10
K2AW-P250-DA	53.8	140	4-M16	100	1/2"	30	80	50	M6	95	M5	14
K3AW-P300-DA	64.4	165	4-M20	130	1/2"	30	80	60	M6	118	M5	18
K4AW-P350-DA	76.9	254	8-M16	200	1/2"	30	80	72	M6	145	M5	20
K5AW-P400-DA	76.9	254	8-M16	200	3/4"	30	80	100	M6	175	M5	20
K6AW-P500-DA	127.4	298	8-M20	230	1"	30	80	120	M6	220	M5	32

Double Acting

Model	Cylinder Capacity (L)		Working Time (S)		Max. Working Pressure (Bar)
	Inside	Outside	Open (Inside)	Close (Outside)	
K1-P200-DA	3.2	3.3	2.0	2.0	0.8
K2-P250-DA	8.0	8.5	2.5	2.5	0.8
K3-P300-DA	13.5	15.0	3.0	3.0	0.8
K4-P350-DA	21.5	24.0	4.0	4.0	0.8
K5-P400-DA	34.0	38.5	5.0	5.0	0.8
K6-P500-DA	69.5	77.0	7.0	7.0	0.8
K7-P600-DA	123.5	129.0	8.0	8.0	0.8
K8-P700-DA	207.0	214.5	10.0	10.0	0.8

Spring Acting

Model	Cylinder Capacity (L)		Working Time (S)		Max. Working Pressure (Bar)
	Inside	Outside	Open (Inside)	Close (Outside)	
K1-P200-SR2	3.2	—	2.5	3.0	0.8
K2-P250-SR2	8.0	—	3.0	3.5	0.8
K3-P300-SR2	13.5	—	4.0	5.0	0.8
K4-P350-SR2	21.5	—	5.0	6.0	0.8
K5-P400-SR2	34.0	—	6.0	7.0	0.8
K6-P500-SR2	69.5	—	9.0	10.0	0.8
K7-P600-SR2	123.5	—	10.0	12.0	0.8
K8-P700-SR2	207.0	—	12.0	14.0	0.8

Air consumption is dependent on air supply pressure, open close stroke, volume and motion times, which is calculated as following:
 $L/Min = \text{Air Volume (Opening Volume + Closing Volume)} * \text{Air Supply Pressure (Kpa)} + 101.3/101.3 * \text{Motion Times (Min.)}$

Common Faults, Inspection and Troubleshooting

Failure Phenomenon	Inspection Item	Solution
Pneumatic valve can not move	1. When solenoid valve is normal, coil is burned or not, or whether solenoid valve core is blocked by foreign matter.	Replace solenoid valve and coils and remove foreign matter
	2. Test the pneumatic actuator separately with air supply, check whether sealing ring and cylinder is damaged.	Replace the damaged sealing ring and cylinder
	3. Impurities in the valve blocks the valve core.	Remove impurities and replace damaged parts
	4. The handle is in manual position.	Move the handle to pneumatic position
Slow motion, crawling	1. Air supply pressure is not enough.	Increase air supply pressure (0.4-0.7Mpa)
	2. Output torque of pneumatic actuator is too small.	Choose a larger pneumatic actuator model
	3. Valve coil or other valve components are too tight.	Reassemble and readjustments
	4. Air supply pipe is plugged and flow is too small.	Clear the plug and replace the filter
Reply devices without signal	1. Short circuit or disconnection of power occurs.	Inspect and repair power circuit
	2. Cam position inside the switch box is not accurate.	Adjust the cam to correct position
	3. Micro switches is damaged.	Replace micro switches

Option: Manual Device

In many applications, the valve/actuator often need the hand wheel device. In the condition of loss of air pressure, we can use the hand wheel to manually open or close the valve. KST has a variety of optional hand wheel products to meet customer requirements, it includes open or closed mechanical hand wheel screw nut, the clutch type mechanical hand wheel gear reducer, hydraulic hand wheel and the storage system.

Hydraulic Manual Device



Declutch Handwheel Device



Mechanical Handwheel Device



Control Panel And Special Solutions

Pneumatic unit, solenoid valve and other components is actuators/valves often involve installed components. KST has a wealth of experience on various fluid power control systems involving and assembly, it can meet the customer's requirements. Our engineers have a deep understanding on the pneumatic control system and hydraulic control system.

Other Accessories





GPRO Valve Sdn Bhd

7, Lot 752 Jalan Subang 3, Tmn. Perindustrian Sg. Penaga,
47610 Subang Jaya, Selangor, Malaysia.
Tel : +603 8023 6900

Whatsapp : +6017 717 6900

E-mail : info@gprovalve.com.my

Website : www.gprovalve.com.my