



Series - GSV1-00

GPRO Safety Valve - Without Lever



Safety Valve Application :

The safety valves are used in mold temperature controller, air compressor, water system, oil pipe, gas system, and so on

Operating Principle :

After installing in the piping system, the safety valve will work automatically when the pressure of medium in the system is reaching to the set value. It releases pressure to protect the system.

1. Max Working Pressure : 4.0MPa
2. For Medium Water, Steam, Gas (non-corrosive)
3. Working Temperature : 220°C

MATERIAL LIST

NO.	PART NAME	MATERIAL
1	Valve Seat	CW617N
2	Butter	CW617N
3	Gasket Ring	PTFE
4	Gasket	/
5	Disc	CW617N
6	Valve Body	BRONZE
7	Spring	SS304
8	Spindle	CW617N
9	Spring Seat	CW617N
10	Adjust Screw	CW617N
11	Cap	CW617N

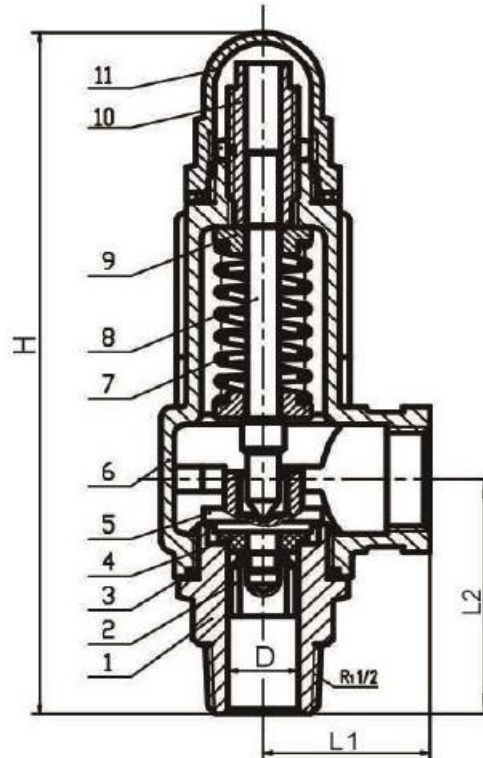

Dimension			Unit : mm			
Inlet	D	Outlet	Lift	L1	L2	H
1/2"	13	1/2"	0.52	31	48	135.5
3/4"	19	3/4"	0.76	35	55	144.5
1"	25	1"	1	39.5	65	175
1-1/4"	31.5	1-1/4"	1.28	50.5	75	197
1-1/2"	37	1-1/2"	1.52	59	86	223.5
2"	47	2"	2	67	100	257

